

NO.	DESCRIPTION
1	GND / MIC+
2	MIC+ / GND
3	R AUDIO
4	L AUDIO / DETECT
5	DETECT / L AUDIO

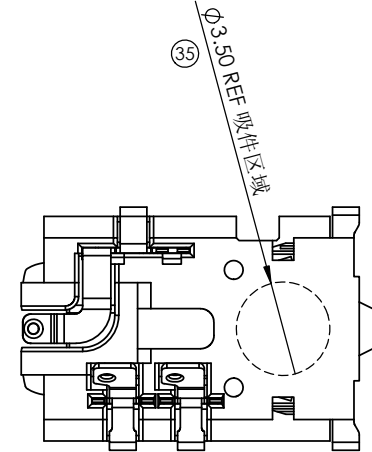

NOTES:  
 1.MATERIAL:  
 HOUSING:PA 9T,BLACK,UL 94HB  
 TERMINAL:1#/2#/3# COPPER ALLOY,T=0.20mm  
 4#/5# STAINLESS STEEL,T=0.20mm  
 PEG: STAINLESS STEEL,T=0.20mm  
 2.ALL DIMENSIONS MARKED (X) MUST BE CONTROLLED BY QC  
 3.ALL DIMENSIONS MARKED (XX) MUST BE MEASURE BY FAI  
 4.PRODUCT SPECIFICATIONS:  
 4-1 WITHSTANDING: 500VAC/MINUTE  
 4-2 CONTACT RESISTANCE: 50 MILLIOHM (initial) Max.  
 4-3 INSULATION RESISTANCE: 100 MEGOHM Min.  
 4-4 MATING AND UNMATING FORCE : 0.8-2.0 Kgf Max. (BTFORE DURABILITY)  
 4-5 MATING AND UNMATING FORCE : 0.6-2.0 Kgf Max. (AFTER DURABILITY)  
 4-6 OPERATION TEMPERATURE : -25° TO +85°  
 4-7 STORAGE TEMPERATURE: -25° TO +85°  
 4-8 DURABILITY : 5000 CYCLES  
 5.PART NO: PH71-0B24 E 36A  
 F: 3U"Min AU PLATING ON CONTACT AREA  
 1U" Min AU PLATING ON SOLDERTAILS AREA

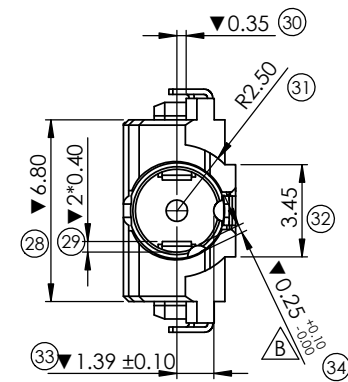
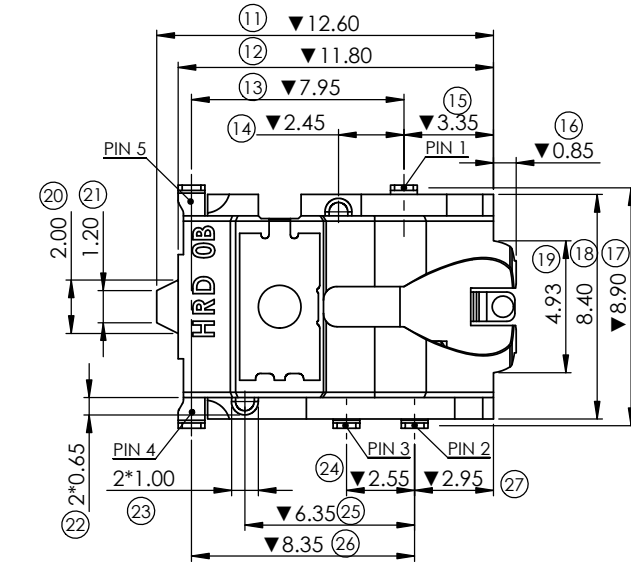
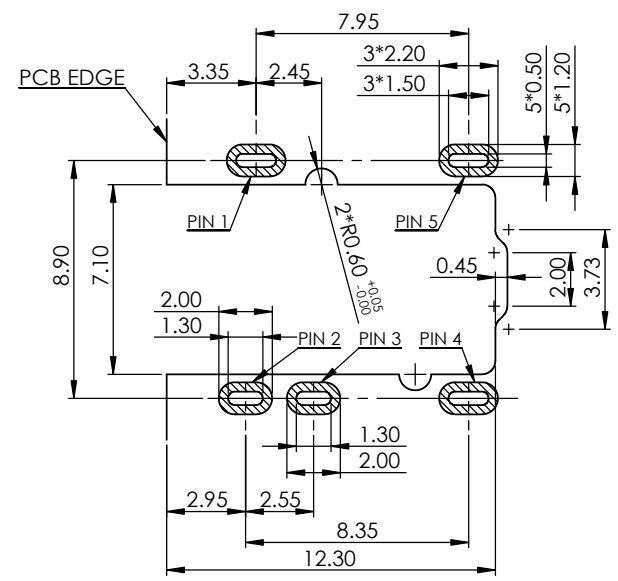
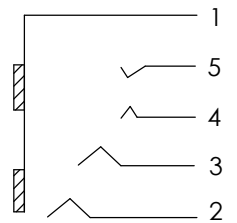
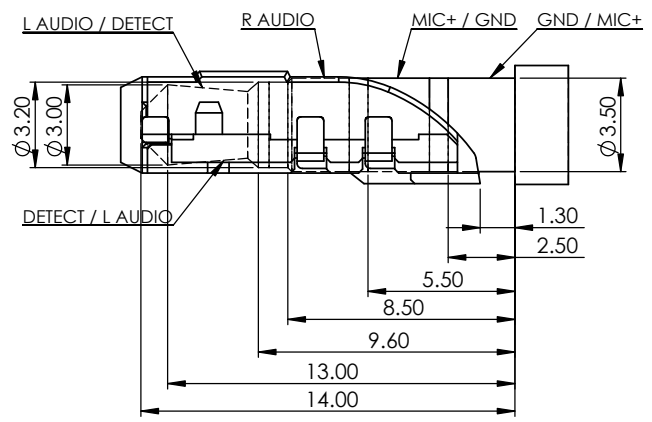

PLUG插入示意图

REV.	ECN NO.	DESCRIPTION	DATE	UNITS: mm	GENERAL TOLERANCE	DRAW:	PART NO:
				DATE: 11/17/2016	X. ±0.20 X' ±0.15 .XX ±0.10 .XXX ±0.05	CHECKED:	PH73-0B14F36A
B	E1612556A	增加弹高尺寸 重点标注	12/20/2016	SCALE: 5/1	X' ±0.10 .XX ±0.05	APPROVE:	TITLE: φ3.50MMC PHONE JACK CONN. 板上1.45mm * 总高3.60mm
A		NEW	11/17/2016	SHEET: 1/2	MATERIAL:		DRAWING NO:
				REV. A	FINISH: SEE NOTE		

**昆山捷皇电子精密科技有限公司**  
 HONGRIDA ELECTRONIC TECHNOLOGY CO., LTD.

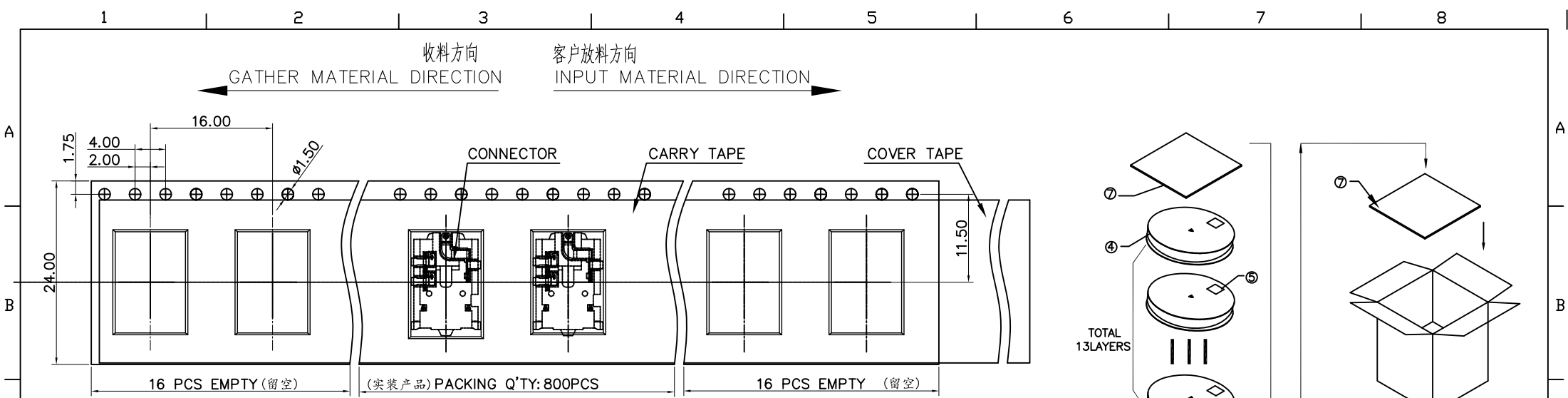

PH73-0B14F36A & 包装示意图

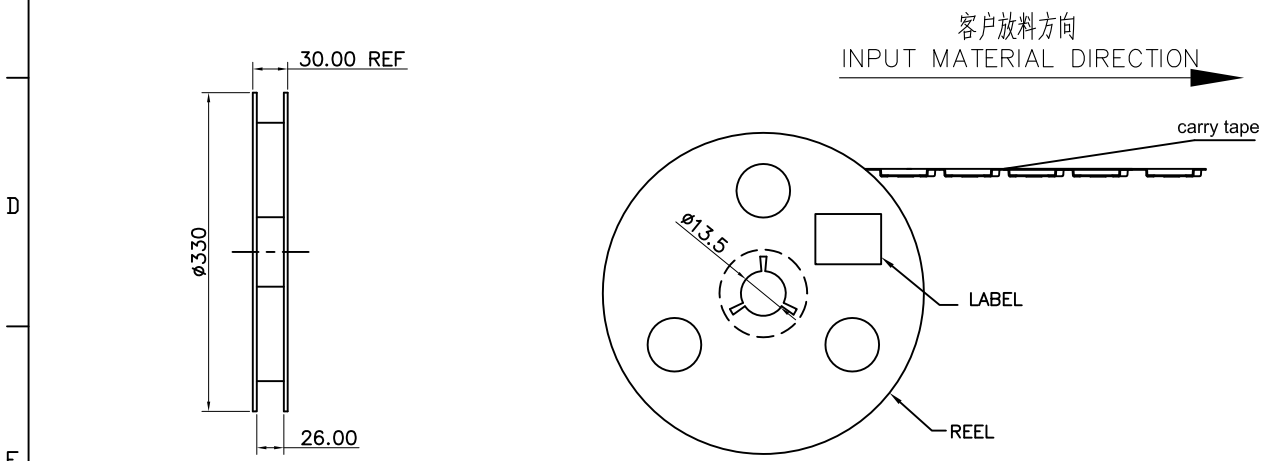

BOM:

NO.	NAME	P/N	SPEC.	Q'TY
①	PHONE JACK	PH73-0B14F36A	DIP	10400PCS
②	CARRY TAPE	R24-PH733600	PS,W=24.0,P=16.0	173.056m
③	COVER TAPE	C24-01000000	PE,W=21.3,T=0.05	173.056m
④	REEL	P24-01000000	φ330,H=24.0	13PCS
⑤	LABEL	L01-01000000		13PCS
⑥	PE袋	G01-10100000	600*700	1PCS
⑦	隔板	D02-01000000	330*330*3	2PCS
⑧	纸箱	W01-01000000	350*350*390	1PCS

NO.	DESCRIPTION	MAT,L	COLOR	REMARK
3				
2				
1	R24-PH733600	PS	WHITE	

				UNITS: mm	GENERAL TOLERANCE		DRAW:	PART NO: PH73-0B14F36A
				DATE: 11/17'2016	X. ±0.20	X.' ±2.00'	CHECKED:	TITLE: φ 3.5MM PHONE JACK CONN.
				SCALE: N/A	.X ±0.15	.X' ±1.00'	APPROVE:	DRAWING NO:
A		NEW	11/17'2016	SHEET: 2/2	MATERIAL:		昆山捷皇电子精密科技有限公司 HRD ELECTRONIC TECHNOLOGY CO.,LTD.	
REV.	ECN NO.	DESCRIPTION	DATE	REV. A	FINISH:			