

1 2 3 4 5 6 7 8

收料方向 GATHER MATERIAL DIRECTION
 客户放料方向 INPUT MATERIAL DIRECTION

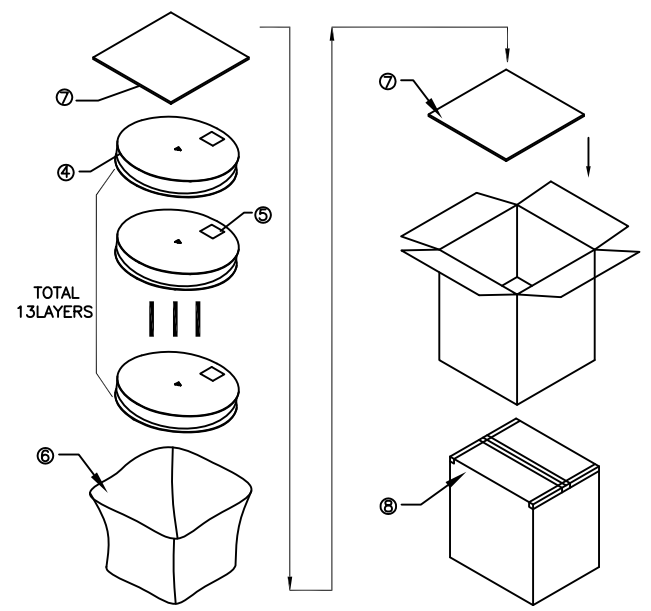
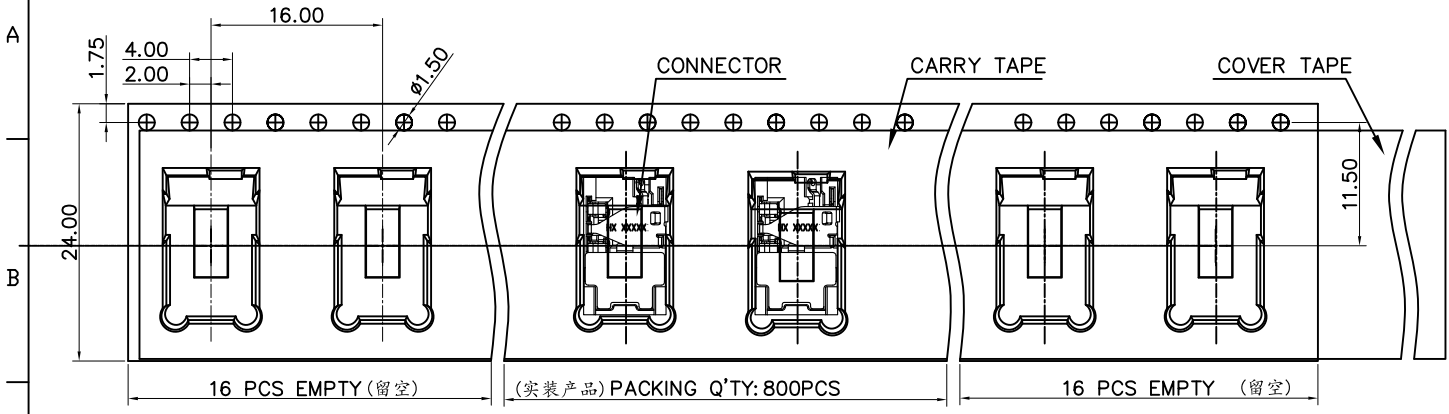

PH92-5B16C42A & 包装示意图

客户放料方向 INPUT MATERIAL DIRECTION

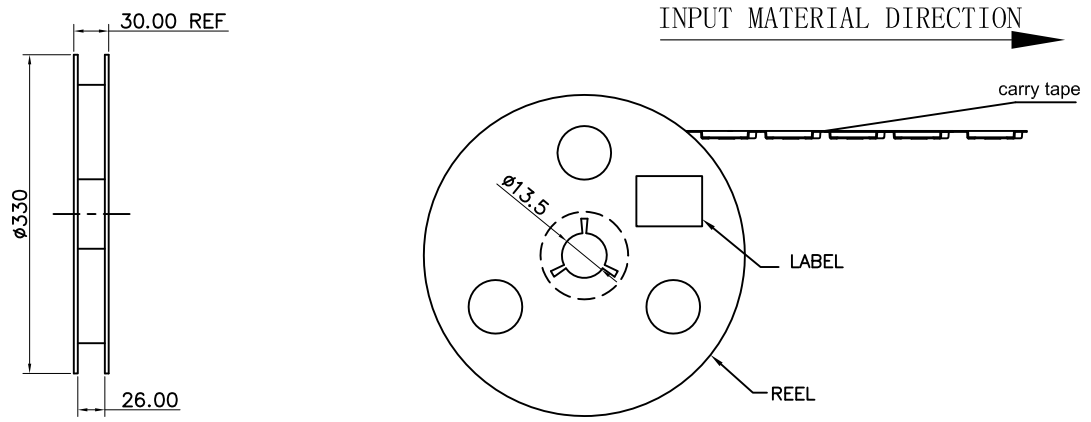

BOM:

NO.	NAME	P/N	SPEC.	Q'TY
①	PHONE JACK	PH92-5B16C42A	DIP	10400PCS
②	CARRY TAPE	R24-PH924800	PET,W=24.0,P=16.0	160.992m
③	COVER TAPE	C24-00100003	PE,W=21.3,T=0.05	160.992m
④	REEL	P24-01100000	$\phi 330,H=24.0$	13PCS
⑤	LABEL	L01-01000000		13PCS
⑥	PE袋	G01-00907007	900*700	1PCS
⑦	隔板	Y03-40036000	330*330*3	2PCS
⑧	纸箱	W01-01353539	350*350*390	1PCS

3				
2				
1	R24-PH924800	PET	WHITE	
NO.	DESCRIPTION	MAT,L	COLOR	REMARK

				UNITS: mm	GENERAL TOLERANCE	DRAW:	PART NO: PH92-5B16C42A
				DATE: 05/03'2018	X. ± 0.20 .X ± 0.15 .XX ± 0.10 .XXX ± 0.05	CHECKED:	TITLE: $\phi 3.5$ MM PHONE JACK CONN.
				SCALE: N/A		APPROVE:	DRAWING NO:
A		NEW	05/03'2018	SHEET: 1/1	TITLE:	昆山捷皇电子精密科技有限公司 HRD ELECTRONIC TECHNOLOGY CO.,LTD.	
REV.	ECN NO.	DESCRIPTION	DATE	REV. A	FINISH:		

1 2 3 4 5 6 7 8