

Date Code 编码月份日期机台号对照码			
月份/日期/机台号	镭雕码	月份/日期/机台号	镭雕码
1	1	17	H
2	2	18	J
3	3	19	K
4	4	20	L
5	5	21	M
6	6	22	N
7	7	23	P
8	8	24	Q
9	9	25	R
10	A	26	S
11	B	27	T
12	C	28	U
13	D	29	V
14	E	30	W
15	F	31	X
16	G	* 字母 I 和 O 不用	

D/C ANNOTATION:
 X X XX X X X
 PLATED LINE H=HRD
 LINE 1=1# LINE
 CLASS D=DAY N=NIGHT
 DATE 11=1/1
 YEAR 9=2019
 COMPANY J=HRD

ITEM	PART NAME	Q'TY	MATERIAL/FINISHED
7	CAP	1	THERMOPLASTIC UL94V-0
6	CONTACT-2	4	ALL:80u" Min. Ni PLANTING FUNCTION AREA:30u" Au PLANTING
5	CONTACT-1	4	
4	LATCH I/M	1	THERMOPLASTIC UL94V-0
3	LATCH	1	STAINLESS STEEL ALL:80u" Min. Ni PLANTING
2	SHELL	1	STAINLESS STEEL ALL:80u" Min. Ni PLANTING
1	HOUSING	1	THERMOPLASTIC UL94V-0

PIN DESCRIPTION											
A12	A11	A10	A9	A8	A7	A6	A5	A4	A3	A2	A1
GND	RX2+	RX2-	VBUS	SBU1	D-	D+	CC1	VBUS	TX1-	TX1+	GND
GND	TX2+	TX2-	VBUS	CC2	D+	D-	SBU2	VBUS	RX1-	RX1+	GND
B1	B2	B3	B4	B5	B6	B7	B8	B9	B10	B11	B12

REV.	ECN NO.	DESCRIPTION	DATE	REV.	FINISH:	SEE NOTE
B		X1,MX1	04/25/2020'			
A		NEW	12/11/2019'			

UNITS:	GENERAL TOLERANCE		DRAW:	PART NO:
mm	X. ±0.25	X.° ±2.00°	CYH	UC32-0X1253R0
DATE:	.X ±0.20	.X° ±1.00°	CHECKED:	NAME:
12/11/2019'	.XX ±0.15	.XX° ±0.50°	/	UC32 ASS'Y
SCALE:	.XXX ±0.10	.XXX° ±0.10°	APPROVE:	DRAWING NO:
5 / 1			FYI	C-UC32-00-01
SHEET:	TITLE:		DRAWING NO:	
1 / 2	UC32 TYPE-C PLUG		C-UC32-00-01	



1 2 3 4 5 6 7 8

A

B

C

D

E

F

A

B

C

D

E

F

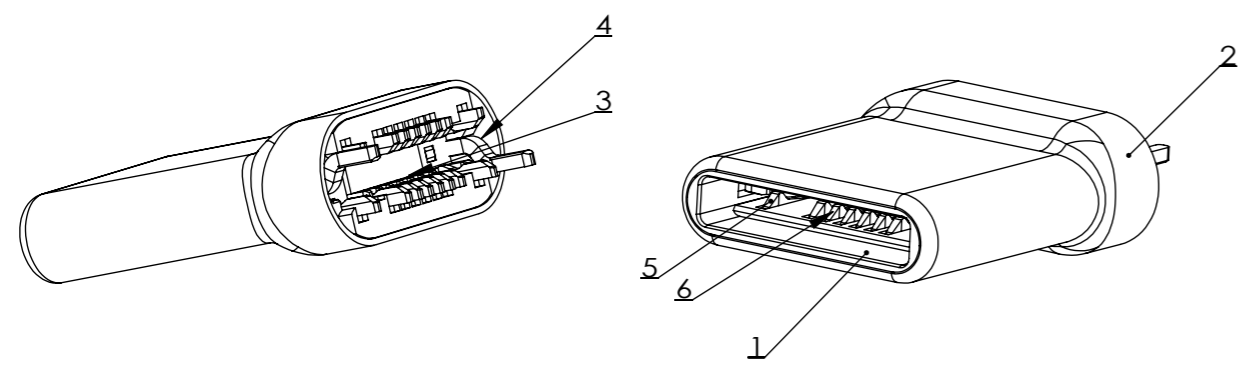
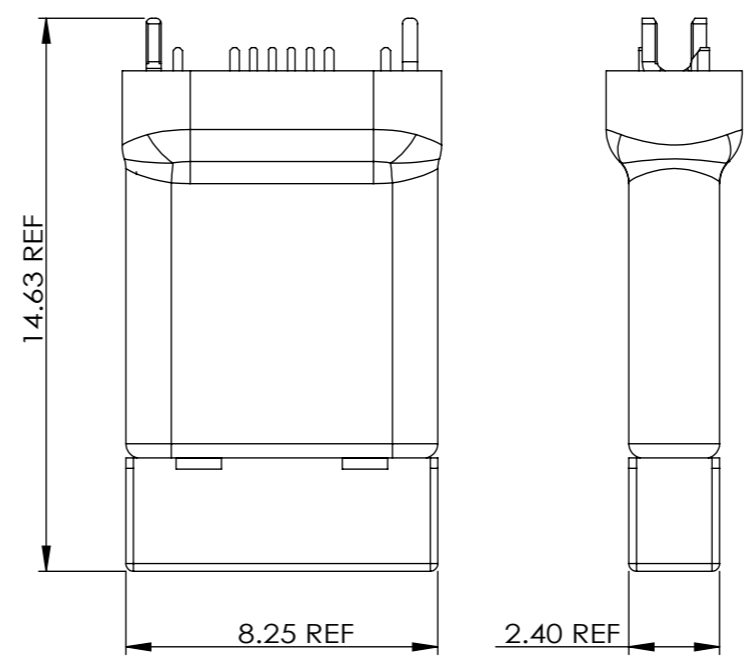
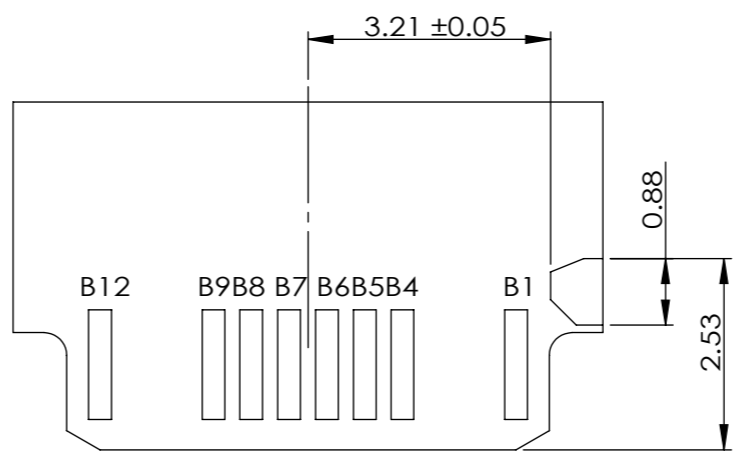
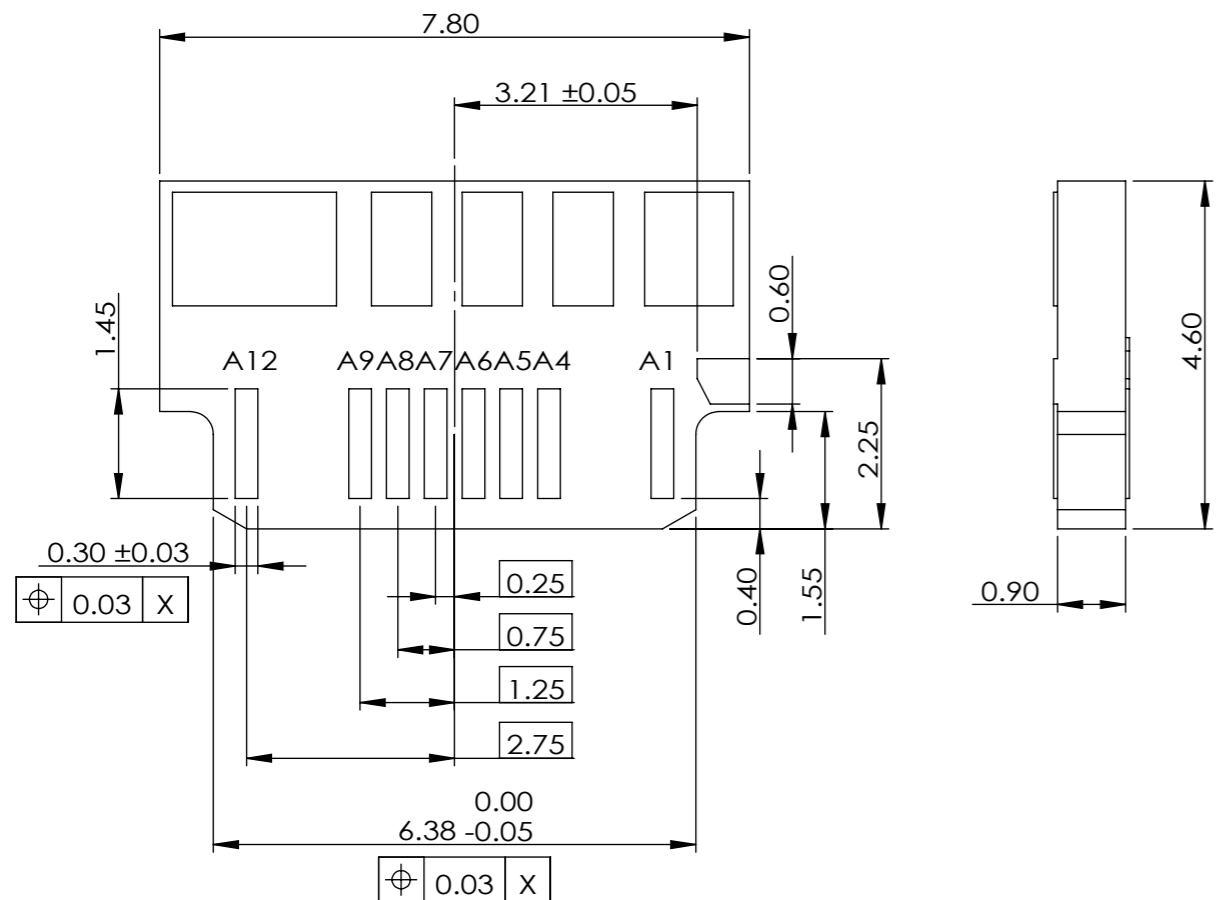

PRODUCT NUMBER CODE
UC32- X X 125 X R 0

1:PRODUCT DESCRIPTION:
UC32:USB 2.0 TYPE C PLUG
DRAWN SHELL TYPE

2:SHELL OF PLATING
0:NI

3:COLOUR OF HOUSING
W:WHITE
B:BLACK
G:GREEN
R:RED
Y:YELLOW

4:PRODUCT LENGTH
L:10.24mm

5:CONTACT PLATING
F: GOLD FLASH ON CONTACT AREA
1: Au 5u'' ON CONTACT AREA
2: Au 15u'' ON CONTACT AREA
3: Au 30u'' ON CONTACT AREA

NOTES
1.MATERIAL:(SEE LEFT TABLE).
2.FINISHED:(SEE LEFT TABLE).
3.PRODUCT SPECIFICATIONS:
3-1. VOLTAGE RATING: 5V.
3-2.CURRENT RATING: VBUS: 5A/4=1.25A PER PIN;
GND: 5A/4=1.25A PER PIN; ALL OTHER PINS: 0.5A MIN.
3-3.INSULATION RESISTANCE: 1000 MΩ MIN.
3-4.WITHSTANDING STRENGTH:100V AC FOR 1 MINUTE.
3-5.CONTACT RESISTANCE: 30 mΩ MAX(INITIAL)
40 mΩ MAX AFTER ENVIRONMENT STRESSES .
3-6.INSERTION FORCE:6~20N
EXTRACTION FORCE:8~20N,AFTER DURABILITY:6~20N
3-7.DURABILITY: 10000 CYCLES.
4. RoHS OR HF COMPLIANT.
5. No SECONDARY MATERIAL IS ALLOWED.
6. MARK IS IMPORTANT DIMENSIONS,
MARK IS CPK(>1.33) DIMENSIONS
AND MUST BE MEASURED BY QC AND IPQC.

CAP示意图

				UNITS: mm	GENERAL TOLERANCE		DRAW: CYH	PART NO: UC32-0X1253R0
				DATE: 12/11/2019'	X. ±0.20	X.° ±2.00°	CHECKED: /	NAME: UC32 ASS'Y
B		X1,MX1	04/25/2020'	SCALE: 5 / 1	.X ±0.10	.X° ±1.00°	APPROVE: FYI	DRAWING NO: C-UC32-00-01
A		NEW	12/11/2019'	SHEET: 2 / 2	.XX ±0.05	.XX° ±0.50°	TITLE: UC32 TYPE-C PLUG	
REV.	ECN NO.	DESCRIPTION	DATE	REV. B	FINISH: SEE NOTE			鸿日达科技股份有限公司 HONGRIDA ELECTRONIC TECHNOLOGY CO.,LTD.

1 2 3 4 5 6 7 8